

EDGEHALT®

Posi-Stop Ladder Safety Gate



Installation Instructions/Operation and Maintenance Manual

Patents Pending

Models:

- LSGPS-1520 LSGPS-2030
- LSGSPD-2030 LSGSPD-3040 LSGSPD-4060

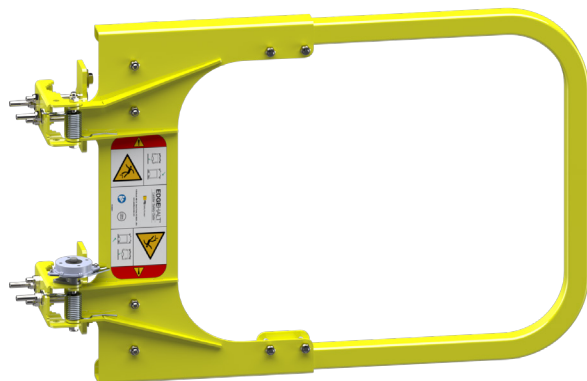

Table of Contents:

- Safety Precautions 2
- Product Information 2
- Operation 3
- Standard Round Installation 4
- Installation on Angle Iron or Square Railing 9
- Installation on Flat Bar or Wall Surface 10
- Replacement Parts List 11
- Replacement Parts Diagram 13
- Inspection and Maintenance 14
- Warranty Certificate 15

Contact Information

<p>Mail PS Safety Access 1150 South 48th Street Grand Forks, ND 58201</p>	<p>Local Phone 701.746.4519</p> <p>Toll Free Phone 877.446.1519</p>	<p>Website pssafetyaccess.com</p> <p>Email 4psinfo@psindustries.com</p>	<p>Hours of Operation 8 A.M. to 5 P.M. CT Monday – Friday</p>
--	---	---	--

IMPORTANT! Read entire Instruction and Operations Manual to become familiar with the product.

NOTICE This product is a fall protection product. The effectiveness of the product is directly related to the proper installation and operation of this product. Failure to properly maintain this product **will** affect performance.

Publication Notice

This manual has been compiled and published covering the latest product descriptions and specifications.

The contents of this manual and the specifications of this product are subject to change without notice.

PS Safety Access™ reserves the right to make changes without notice in the specifications and materials contained herein and shall not be responsible for any damages (including consequential) caused by reliance on the materials presented, including but not limited to typographical and other errors relating to the publication.

PS Safety Access and/or its respective suppliers may make improvements and/or changes in the product(s)/ service(s) offered and/or the program(s) at any time without notice.

Retain this manual for future reference.

If you would like to download a copy of this manual, please go to pssafetyaccess.com

Product registration is an essential step to protecting your product, register Online at psindustries.com/contact/register-your-product/



Safety Precautions

The following icons are used throughout this Manual.

- ▲ DANGER** Indicates an imminently hazardous situation which, if not avoided, will result in death or serious injury.
- ▲ WARNING** Indicates a potentially hazardous situation which, if not avoided, could result in death or serious injury.
- ▲ CAUTION** Indicates a potentially hazardous situation which, if not avoided, may result in minor or moderated injury.
- NOTICE** Indicates manufacturer's statement of additional information.
- IMPORTANT!** Indicates a required action.
- CRITICAL** Indicates a vital component to product performance.

Product Information

NOTICE Unauthorized modification of or to the Product voids this Limited Warranty. Authorized modifications, received in writing from PS Industries® Incorporated, as long as the modification is accomplished in strict accordance with PS Industries' instructions, does not void warranty. If this product is modified or altered without manufacturer's permission, manufacturer is no longer responsible for the product design, engineering, or performance and owner assumes all responsibility. To request product modifications contact PS Industries Incorporated, 1150 S. 48th Street, Grand Forks, ND 58201, phone 877-446-1519, email: 4psinfo@psindustries.com

I. General Information

- A. This manual contains information regarding installation, operation, and maintenance of the PS Safety Access' EdgeHalt® Posi-Stop Ladder Safety Gate.
- B. PS Safety Access recommends that the owner implement a regular preventative maintenance program to inspect and maintain the Posi-Stop Ladder Safety Gate at a minimum, in accordance with the recommendations in this manual.

II. Operation Guidelines

- A. The Posi-Stop Ladder Safety Gate is designed to meet:
 1. OSHA Railing Standard 1910.29(b).; ANSI A1264.1-2017; Canada OHS Part II (SOR-86-304)
- B. Operation in a manner other than intended could result in damage or less than acceptable performance at time of need, for which the manufacturer will not be held responsible.

III. Safety Precautions

- A. Ensure opening is clear of all obstructions through the entire proposed travel of the Posi-Stop Ladder Safety Gate during operation.
- B. Comply with all OSHA and ANSI Safety Regulations and/or company safety policies when installing.

▲ WARNING Do NOT force components if they do not operate freely.

▲ DANGER Ensure area below installation is blocked off from personnel during installation, and mounting surface is capable of supporting all loading. Structural analysis of mounting surface is the responsibility of the owner.

▲ CAUTION For products that are approved for use as a means of fall protection, the product only serves as a means of fall protection when the product is in the closed position.

IMPORTANT! Due to variances in field conditions, it is the responsibility of the installer to ensure that the product is installed to mounting surface that is capable of supporting all imposed loading from the product. The installer is responsible for ensuring that the field configured mounting arrangement is capable of supporting all field loads and meets applicable codes and regulations. Refer to the anchor manufacturer's installation instructions for installation requirements.

IV. Storage Prior to Installation of Product

- A. Store materials in a dry, ventilated location. If outdoor storage is required, block materials and tarp in a tent-like arrangement, elevated above the product with open sides to allow airflow.

V. Installation Site Preparation

NOTICE Before starting site preparation and installation of the Posi-Stop Ladder Safety Gate, read the entire Operation and Maintenance Manual and review all additional installation instructions thoroughly.

- A. Clear work area of any debris.
- B. Ensure you have the necessary tools available.
- C. Obtain all required permits.
- D. Personnel: Determine the appropriate number of personnel required to perform installation and have them readily available at the project site (1-2 people recommended).
- E. Ensure all installation personnel utilize appropriate fall protection equipment and procedures during installation.

VI. Recommended Tools for Installation:

- A. Tools:
 1. One (1) $\frac{1}{2}$ " Deep-well Socket and Ratchet
 2. One (1) $\frac{3}{4}$ " Deep-well Socket and Ratchet
 3. One (1) Wrench Set
 4. One (1) Tape Measure
 5. One (1) Torque Wrench
 6. One (1) Impact Drill w/ drill bit
 7. Depending on anchoring configuration, additional tools may be required.

VII. Posi-Stop Ladder Safety Gate Part List

- A. Review inventory to ensure all parts are present for assembly/installation. Refer to part list below.

Posi-Stop Ladder Safety Gate Part List (As shipped)

ITEM #	DESCRIPTION	QTY
1	LSGPS;HINGE PLATE ASM*	1
2	LSGPS;HOOP*	1
3	LSGPS;HARDWARE KIT	1
4	LSGPS;STOP PLATE	2
5	LSGPS;HINGE STOP BRKT	2
6	LSG;SLAM-PROOF KIT~	1

*Shape is dependent on Gate Opening Size.
~0°F-130°F recommended operating range.

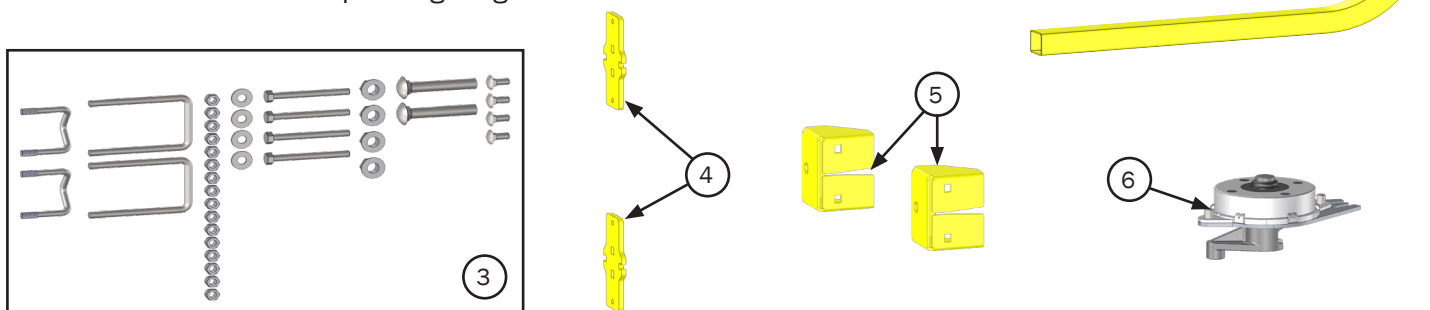

VIII. Operation

- A. Follow your employer's safety policies and local safety codes when utilizing the Posi-Stop Ladder Safety Gate and ladder.
- B. Always maintain at least three points of contact to the ladder or ladder extensions when climbing and passing through the Posi-Stop Ladder Safety Gate opening. **DO NOT USE THE POSI-STOP LADDER SAFETY GATE AS A GRAB SURFACE.**
- C. Ensure the gate returns to a closed position.

Standard Round and Square Installation

IX. Standard Round and Square Installation

A. Railings up to 2" O.D. round and up to 1.75" square.

- STEP 1.** Loosely hang the Hinge Plate Assembly to align with top of railing.
- If no railing, adjust top of gate to 42" above walking surface.
 - Tighten the Hinge Plate Assembly to the railing with $\frac{5}{16}$ " U-bolts, washers, and nylock nuts.

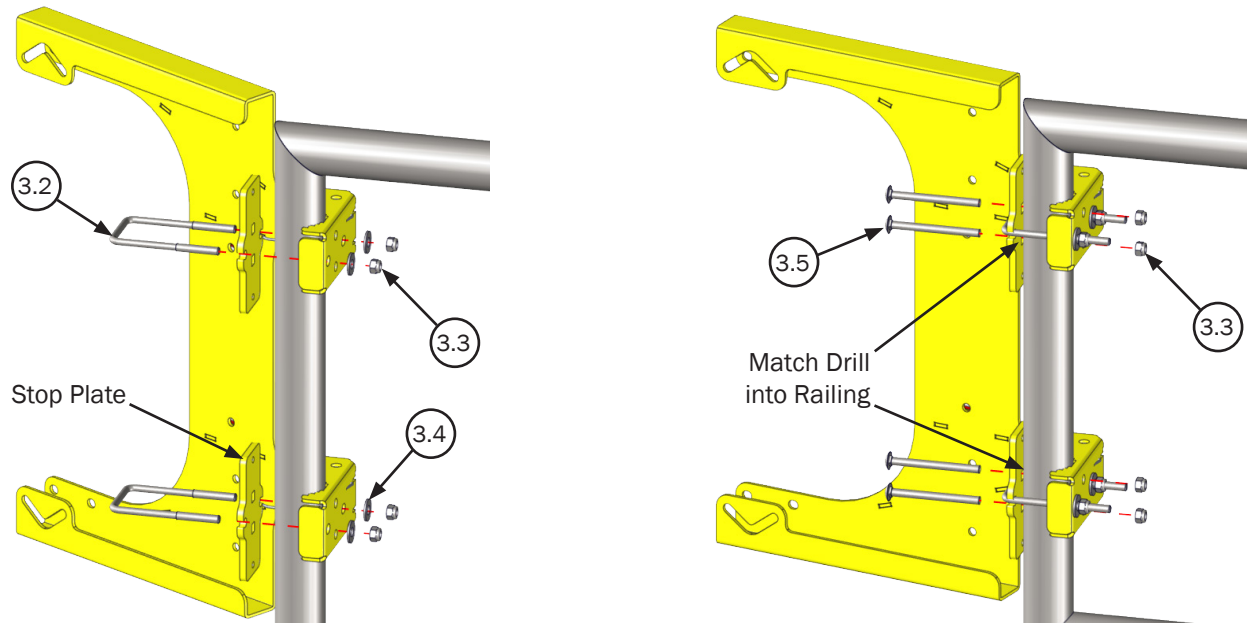

- STEP 2.** Align railing/mounting bracket to be perpendicular (90°) to Ladder Safety Gate opening (refer to **STEP 6**).
- Match drill holes in Stop Plate and Hinge Brackets into railing.
 - Insert $\frac{5}{16}$ " carriage bolts and nylock nuts.

CRITICAL Tighten each U-bolt to 20 ft*lbs of torque and field verify for adequate attachment.

- STEP 3.** Slide Hoop into the Hinge Plate.
- Insert Vice Bolt and hand tighten the nuts.

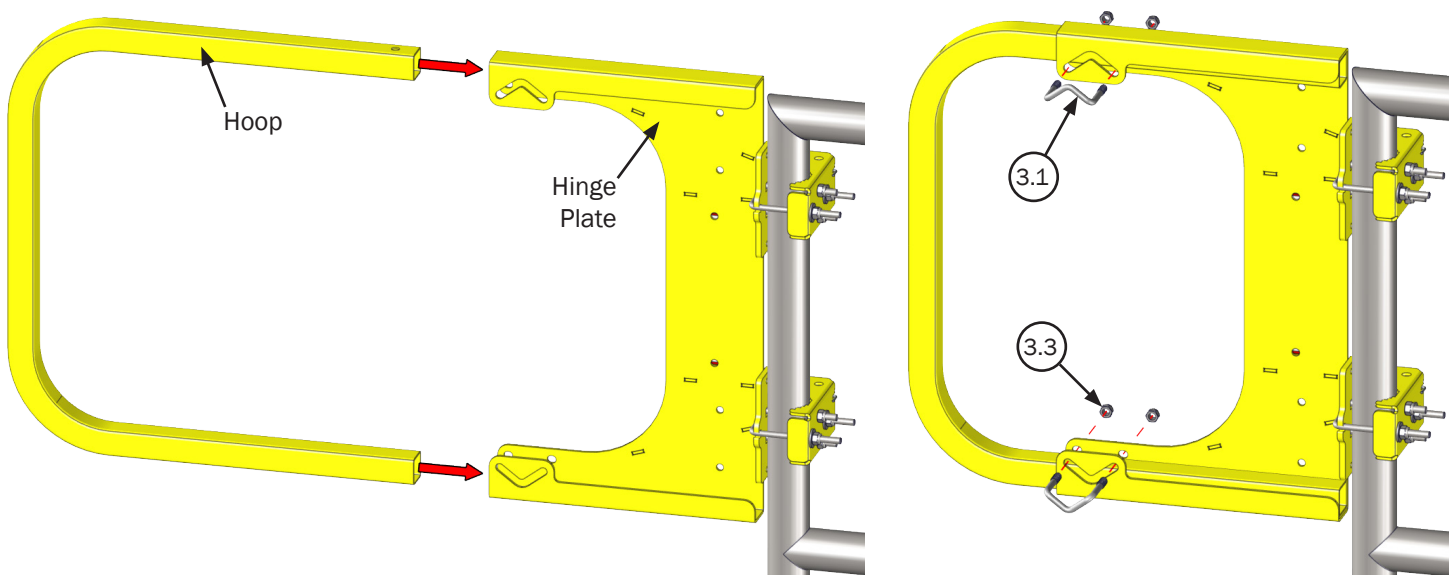

STEP 4. Position the Hoop within the adjustment range and ensure gate is flush with the opposite railing.

- Tighten Vice Bolts to 10ft*lbs.
- Install Strike Pad in a location where it protects contact between the Strike Plate and the railing.

CRITICAL VERIFY INSTALLATION

- End of the Hoop is within the Hoop Adjustment Range illustrated.
- Tighten Vice Bolts to 10 ft*lbs. Two (2) nuts per Vice Bolt.

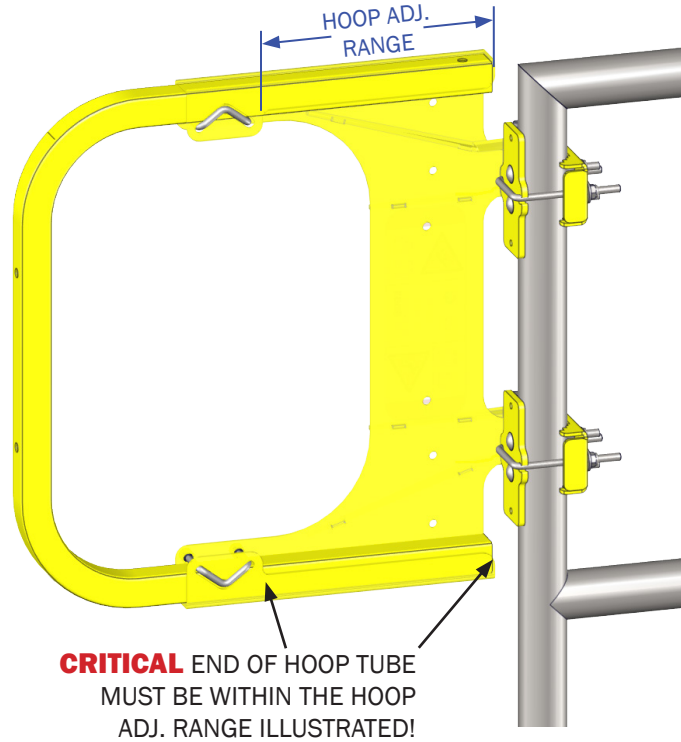

STEP 5. Attach one (1) $\frac{1}{2}$ " carriage bolt and flange nut into each Hinge Stop Bracket.

- Install Hinge Stop Brackets on Hinge Plate using $\frac{5}{16}$ " carriage bolts and nylock nuts.

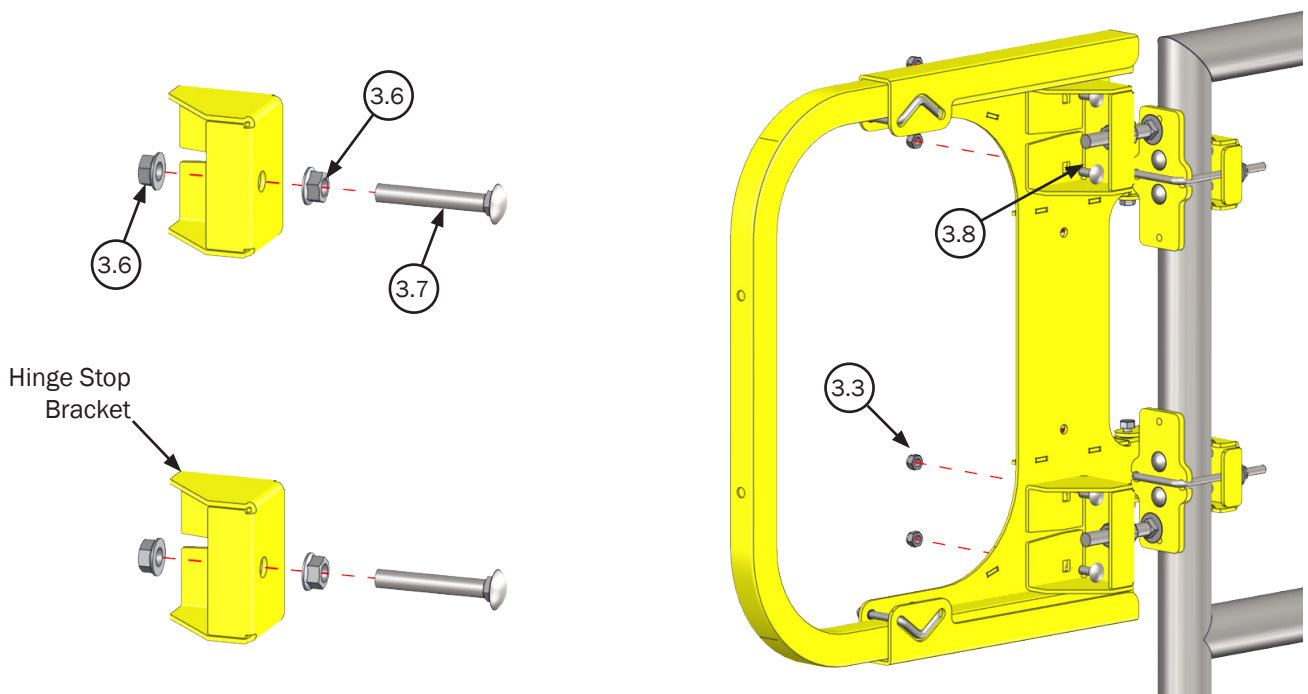

STEP 6. Set gate flush in railing opening.

- a. Using 1/2" carriage bolts and flange nuts; equally adjust bolts to both contact the stop plates when the gate is closed.

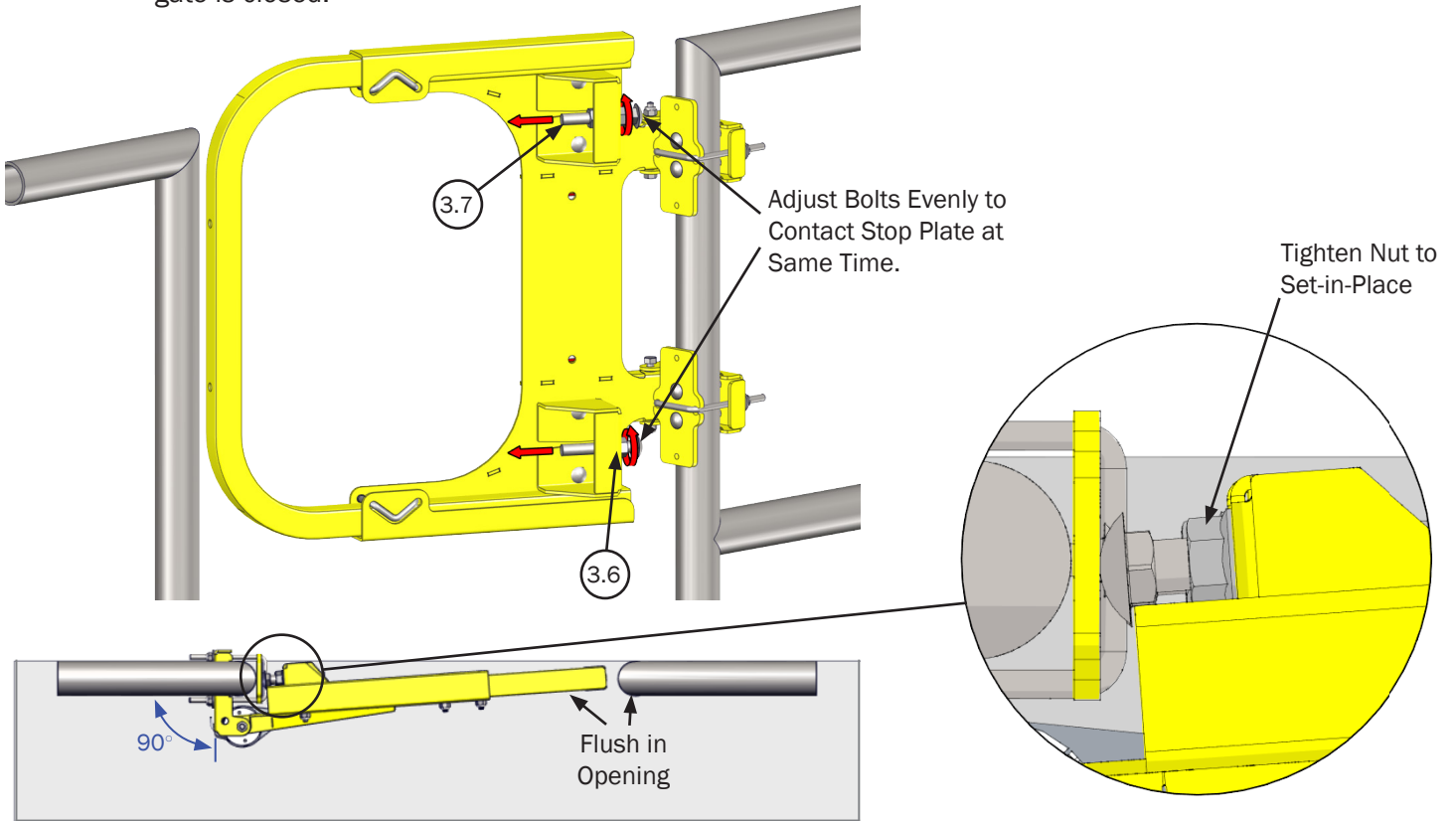

STEP 7. Installation of Slam-Proof™ Damper Kit is recommended, but it is not required. The Slam-Proof™ Damper Kit controls the closing speed of the gate in order to eliminate slamming and noise.

NOTICE Damper is recommended for use between 0°F and 130°F.

NOTICE Damper can be installed in either orientation on either hinge location, as long as it is installed on the hex head of the bolt (not the nut).

- a. Slightly loosen hinge bolt on chosen hinge (top or bottom), do NOT remove nut.
- b. Push hinge bolt up but not out of the hinge.
- c. Slide Damper Stud onto the hex head of the bolt (not the nut).

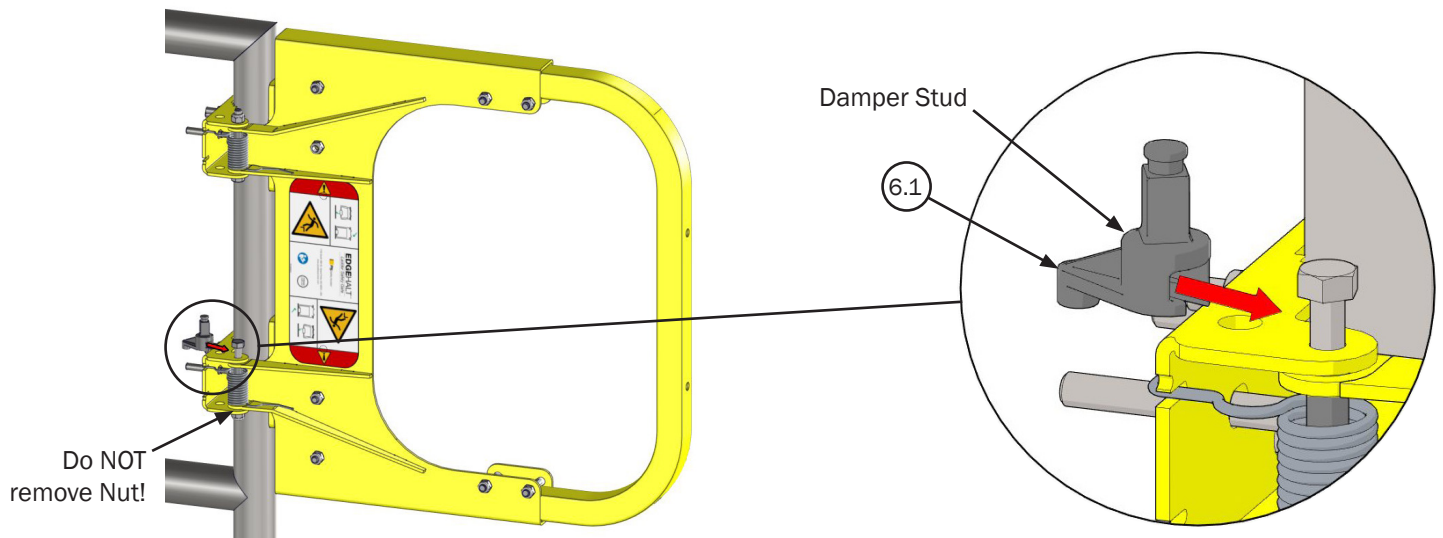

STEP 7. Continued

- d. Align the Damper Stud with the receiving hole in the Hinge Bracket.
- e. Push the Damper Stud flush with the Hinge Bracket (aligning the pin/hole).
- f. Carefully tighten the nut of the hinge bolt until the damper stud is in contact with the Hinge Bracket, and add an additional half turn to the nut.

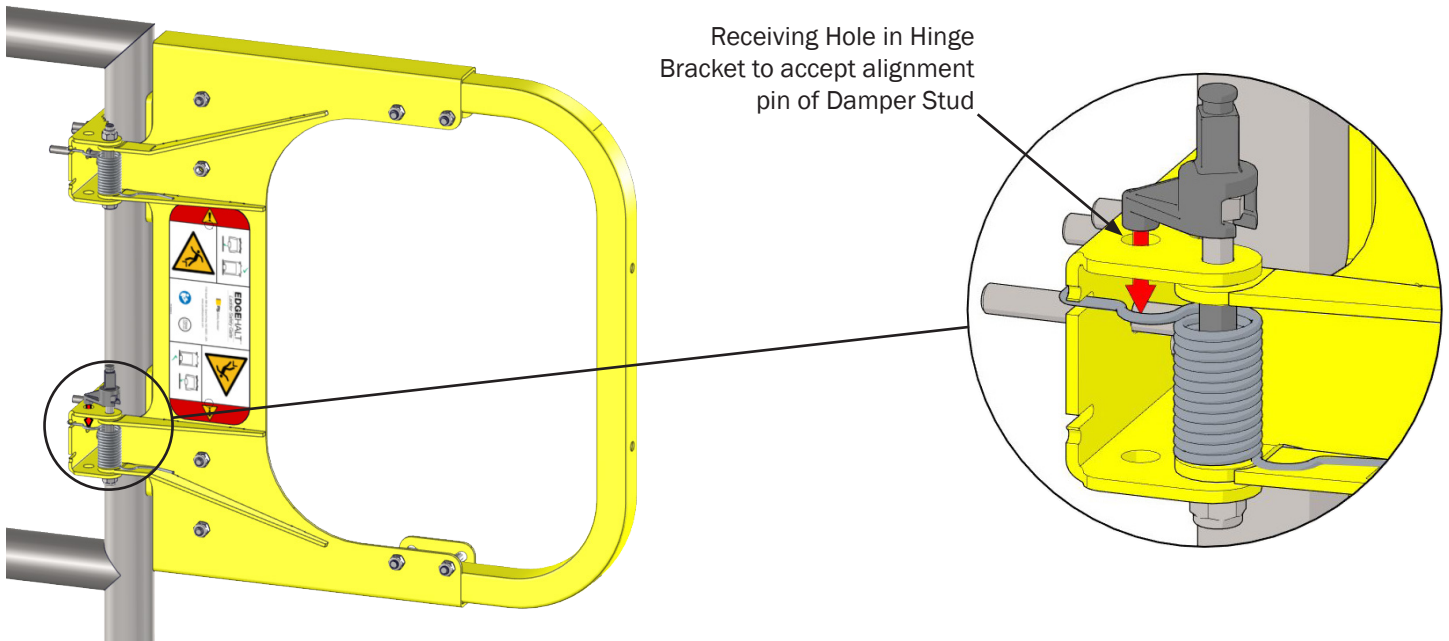

CRITICAL Do not over-tighten hinge bolt. Over-tightening the hinge bolt will bend the Hinge Bracket tight around the Hinge Plate bushings. If this occurs, loosen nut by a half twist to ensure the hinge pivots/operates freely.

- g. Align the slot in the damper plate with the Hinge Plate edge and slide Damper down over the top of the Damper Stud. If necessary, rotate the gate until all components align.

NOTICE Damper case is zinc plated steel and not recommended for long-term exposure to harsh or corrosive chemicals or environments. It is the responsibility of the installer to determine if environmental conditions are suitable for damper use.

- h. Lastly, install the O-ring over the top of the Damper Stud to retain Damper in place.

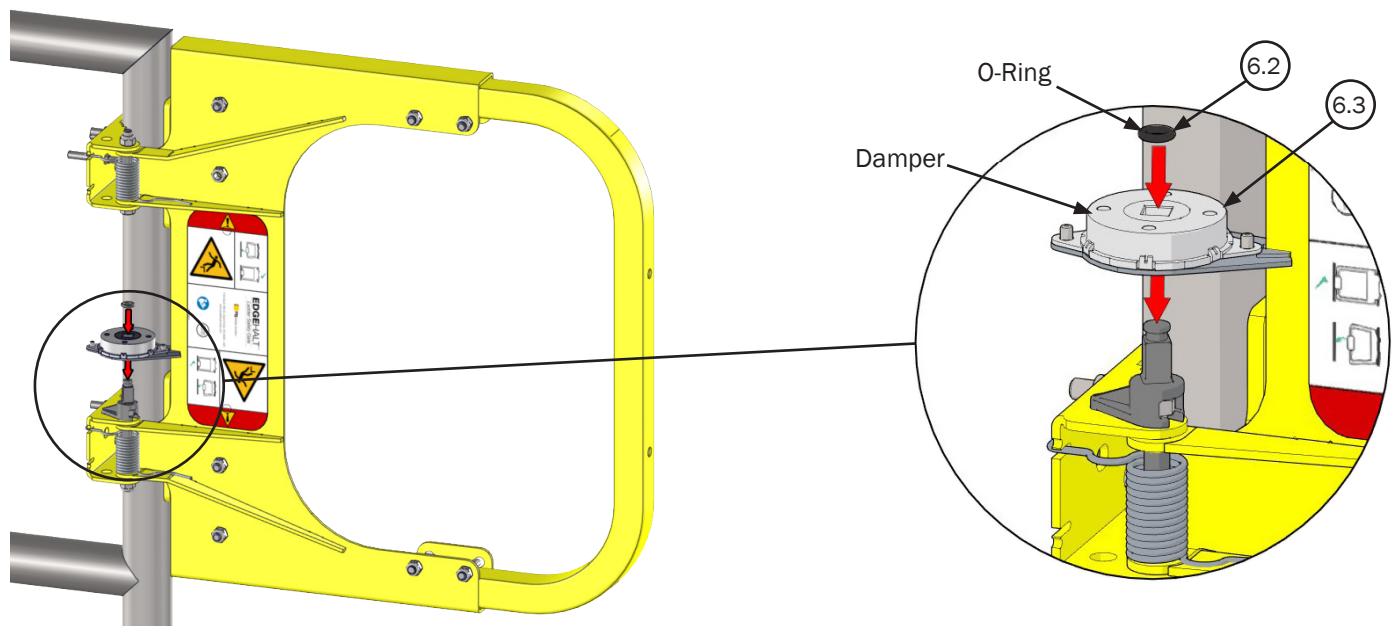

- STEP 8. OPTIONAL ADJUSTMENT:** Adjust Spring tension/action by choosing one of the two grooves in the back of the hinge bracket and placing spring leg in slot.
- a. Short notch is for more of “snappy” closing (faster with more force).
 - b. Deeper slot is for a slower closing force.

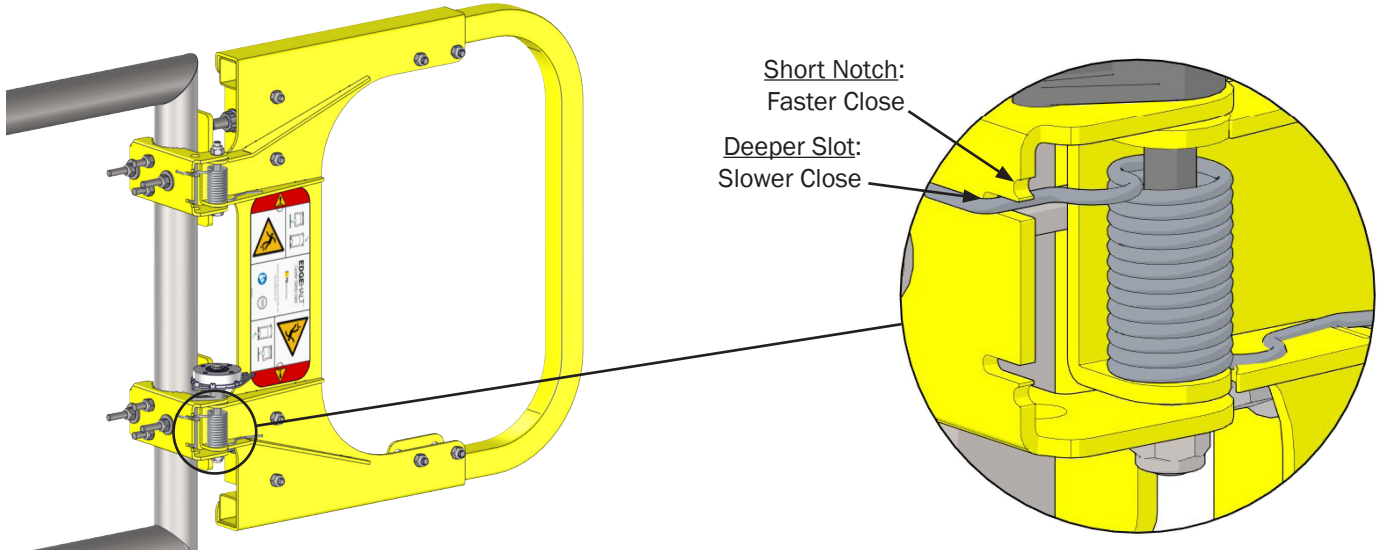

STEP 9. FOR DOUBLE GATES:

- a. Refer to Measuring Guide for assistance in accurate gate gap clearances for your rough opening.
- b. Follow **STEP 1** through **STEP 7** for second gate.

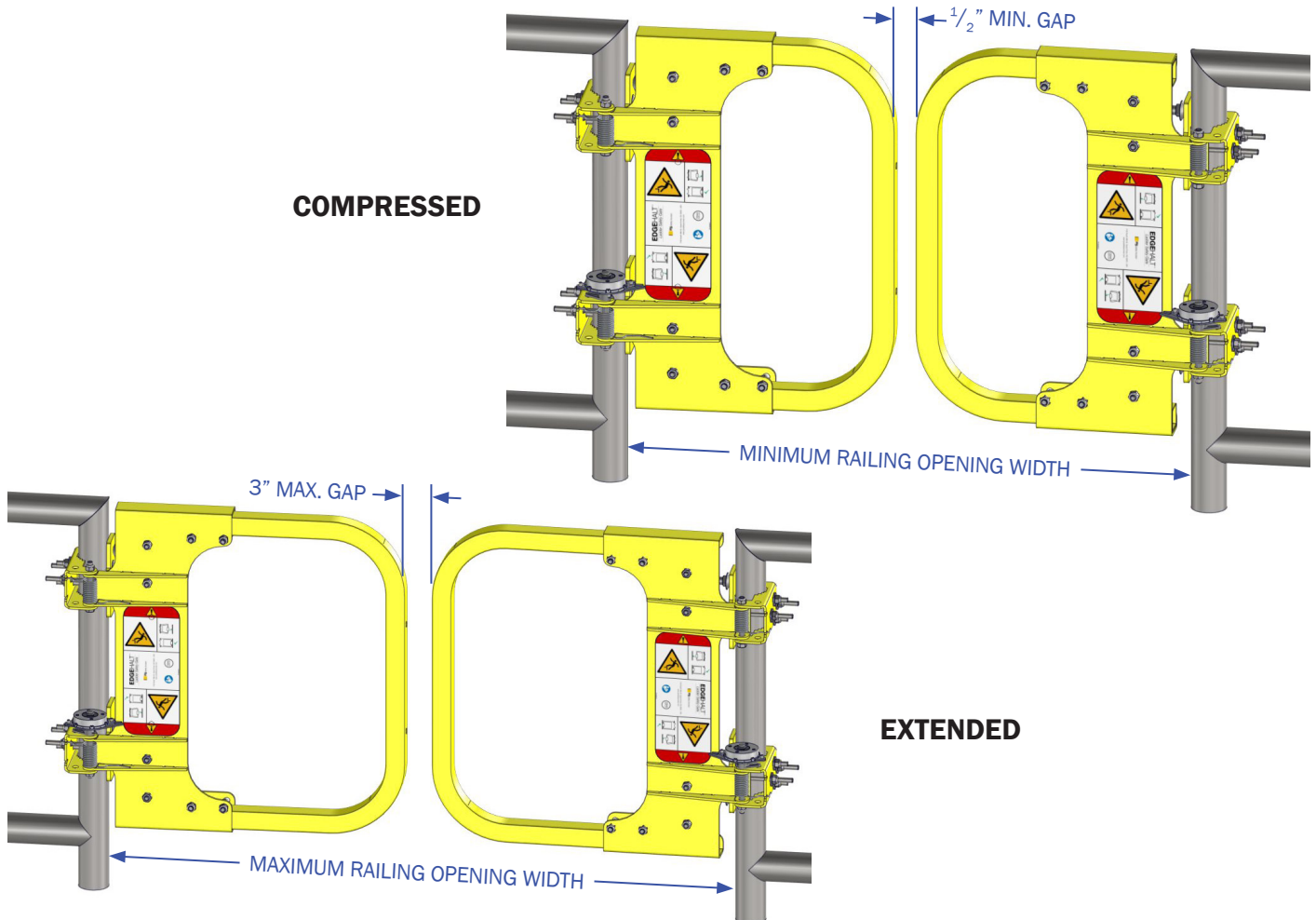

Installation on Angle Iron or Square Railing

X. Installation on Angle Iron or Square Railing (supplied by the Installer)

NOTICE If mounting your Ladder Safety Gate to angle iron or square railing 2" or larger: Gate bolts directly to existing railing (see below installation instructions). If you do not wish to drill into your existing railing system, call PS Safety Access at 877.446.1519 to order a "no drill" adapter bracket.

STEP 1. Align the Ladder Safety Gate Railing Bracket to the inside of the angle iron or square railing.

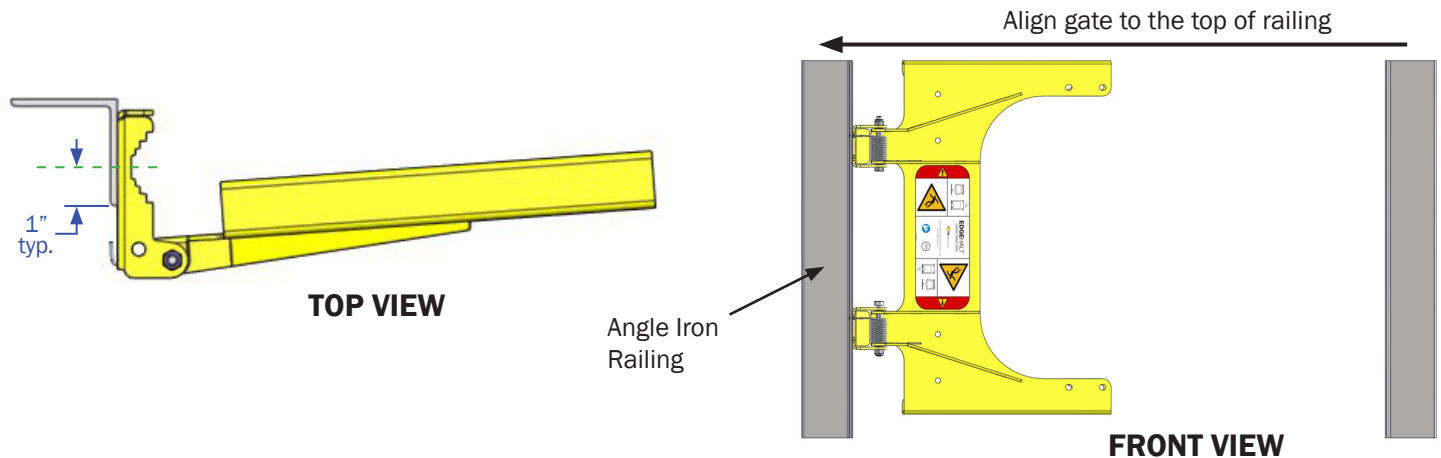

STEP 2. Align top of Ladder Safety Gate to align with top of railing.
a. If no railing, adjust top of gate to 42" above walking surface.

STEP 3. Mark holes and set gate aside.
a. Drill $\frac{5}{16}$ " holes into the railing (one (1) per Railing Bracket).

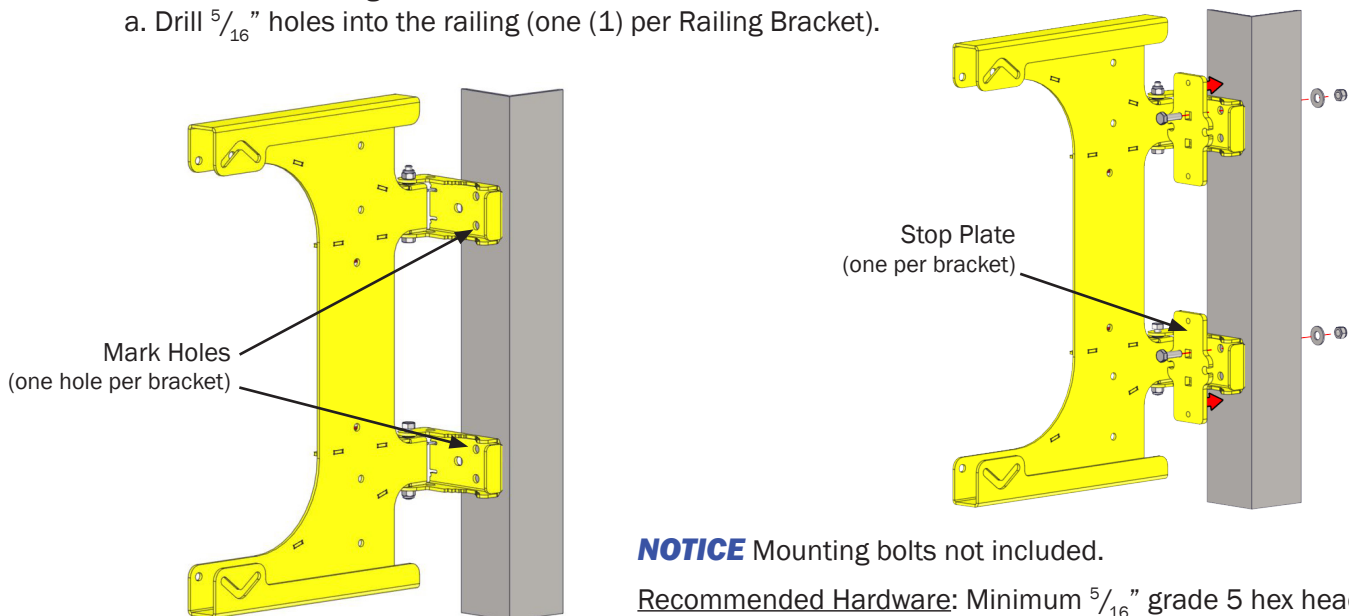

NOTICE Mounting bolts not included.

Recommended Hardware: Minimum $\frac{5}{16}$ " grade 5 hex head bolts of appropriate length with washers and self-locking nuts.

STEP 4. Life gate in place, attach one (1) stop plate per railing bracket.
a. Loosely attach appropriate mounting bolts into railing (mounting bolts provided by the Installer).
b. The stop plate is seated down between the bracket teeth when all bolts are tight.

NOTICE Rest of Gate not shown.

STEP 5. Refer to **STEP 3** through **STEP 7** on Pages 3-7 for remainder of installation

IMPORTANT! If no stop surface is available for the Strike Plate to rest against, install stop surface (Provided by the Installer), using appropriate anchoring hardware and material, to align with the Strike Plate.

Installation on Flat Bar Railing or Wall Surface

XI. XI. Installation on Flat Bar Railing or Flat Wall Surface (supplied by the Installer)

NOTICE If mounting your Ladder Safety Gate to flat bar railing: Gate bolts directly to existing railing (see below installation instructions). If you do not wish to drill into your existing railing system, call PS Safety Access at 877.446.1519 to order a “no drill” adapter bracket.

STEP 1. Align the Ladder Safety Gate Railing Bracket flush to the flat bar/flat wall.

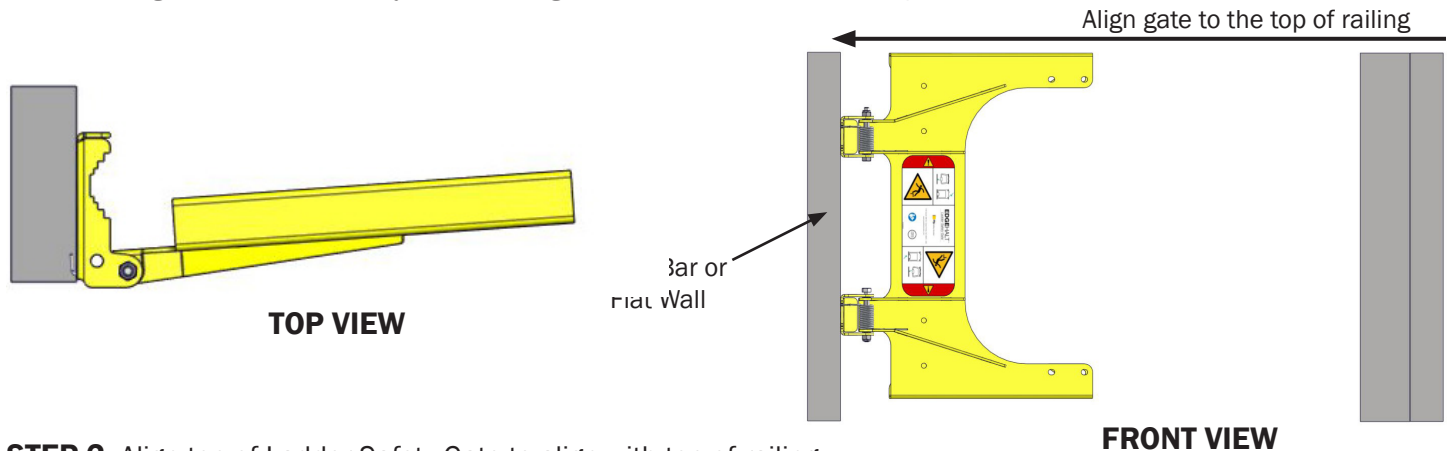

STEP 2. Align top of Ladder Safety Gate to align with top of railing.
a. If no railing, adjust top of gate to 42” above walking surface.

STEP 3. Mark holes and set gate aside.
a. Drill $\frac{5}{16}$ ” holes into the railing (one (1) per Railing Bracket).

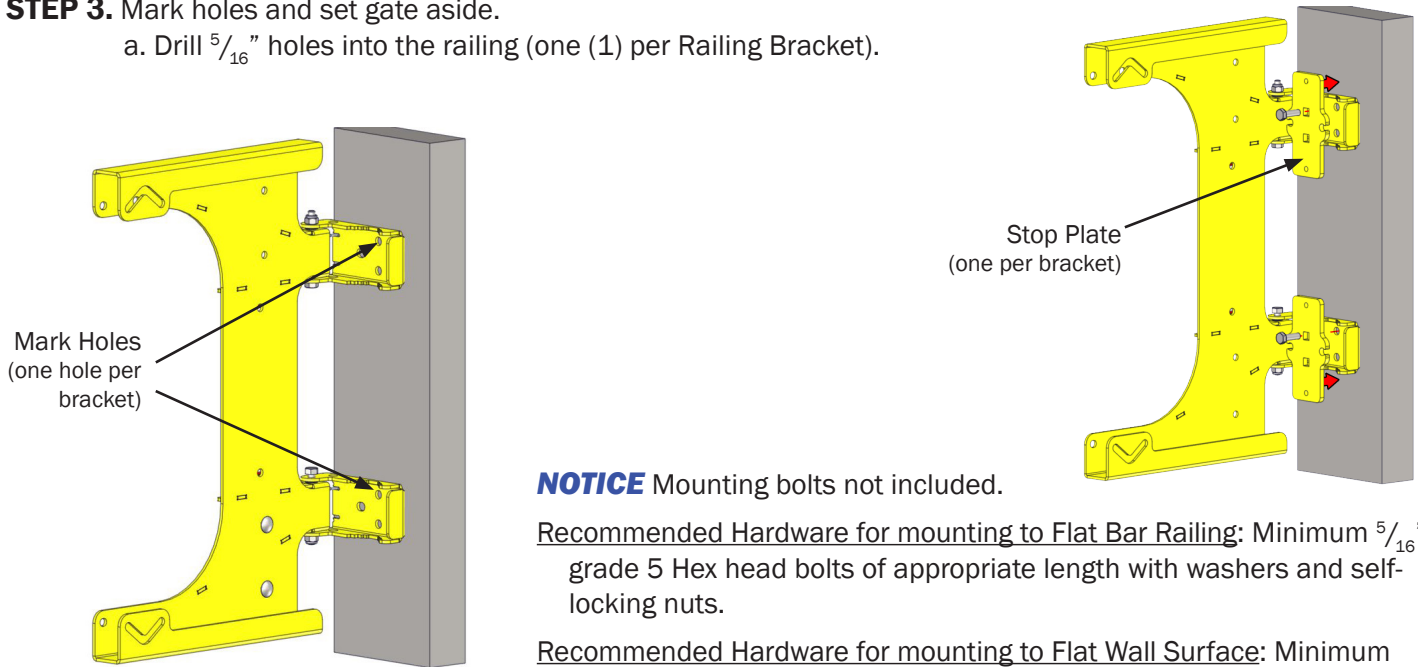

NOTICE Mounting bolts not included.

Recommended Hardware for mounting to Flat Bar Railing: Minimum $\frac{5}{16}$ ” grade 5 Hex head bolts of appropriate length with washers and self-locking nuts.

Recommended Hardware for mounting to Flat Wall Surface: Minimum use mechanical or chemical fastener, sized appropriate, for mounting material and loading requirements.

STEP 4. Life gate in place, attach one (1) stop plate per railing bracket.
a. Loosely attach appropriate mounting bolts into railing (mounting bolts provided by the Installer).
b. The stop plate is seated down between the bracket teeth when all bolts are tight.

NOTICE Rest of Gate not shown.

STEP 5. Refer to **STEP 3** through **STEP 7** on Pages 3-7 for remainder of installation

IMPORTANT! If no stop surface is available for the Strike Plate to rest against, install stop surface (Provided by the Installer), using appropriate anchoring hardware and material, to align with the Strike Plate.

Replacement Parts List

XII. Replacement Parts List

- A. This Replacement Parts List are for all PCY/GAL/304SW Models.
 B. The Replacement Parts Diagrams are located on Page 13.

FINISH OPTIONS	
304SW	304 Stainless Steel Seal-Welded
PCY	Powder Coat Safety Yellow
GAL	Hot Dipped Galvanized

**For replacement springs, order Torsion Spring Kit (part #511686.) Kit includes (1)LSG Torsion Spring, (2)Bushings and Installation Instructions.

**TO ORDER PARTS CONTACT PS SAFETY ACCESS AT
 877.446.1519 or 4psinfo@psindustries.com**

ITEM #	DESCRIPTION	QTY ¹	Gate Finish Type		
			PCY	GAL	304SW
1	REFER TO HARDWARE VARIANT				
1.1	LSG;HINGE BRACKET	2	515689	515742	515759
1.2	REFER TO HARDWARE VARIANT				
1.3	LSG;TORSION SPRING, STAINLESS	2	501659	501659	501659
1.4	BEARING;G300 FLANGE, .3125ID	4	509753	509753	509753
1.5	BOLT;HEX5/16"18X3	2	500431	500431	508239
1.6	NUT;NYLOCK 5/16"18	2	501126	501126	508995
1.7	DECAL;LSG ANSI DANGER	1	500569	500569	500569
2	REFER TO HARDWARE VARIANT				
3	LSGPS;HARDWARE KIT	1	515847	515847	515848
3.1	LSG;VICE BOLT	2	515623	515623	515624
3.2	BOLT;SQU 5/16"18X3 1/4 PIPE	2	516117	516117	515986
3.3	NUT;NYLOCK 5/16"18	16	501126	501126	508995
3.4	WASHER;FLAT 5/16"	4	501949	501949	508053
3.5	BOLT;CARRIAGE5/16"18X3-1/2"	4	515955	515955	515956
3.6	NUT;FLANGE 1/2"13	4	502903	502903	503936
3.7	BOLT;CARRIAGE1/2"13X3.25	2	516089	516089	516090
3.8	BOLT;CARRIAGE 5/16"X3/4"	4	514333	514333	515686
4	LSGPS;STOP PLATE	1	515789	515799	515812
5	LSGPS;HINGE STOP BRKT	2	515787	515798	515975
6	LSG;SLAM-PROOF KIT	1	515814 (kit only)	515814 (kit only)	515814 (kit only)
6.1	LSG;DAMPER STUD	1			
6.2	O-RING;DASH 203 BUNA-N	1			
6.3	LSG;DAMPER ASSEMBLY	1			

1. All quantities to be doubled for Paired Gates (LSGSPD).

XII. Replacement Parts List Continued

- A. This Replacement Parts List are for all PCY/GAL/304SW Models.
 B. The Replacement Parts Diagrams are located on Page 13.

FINISH OPTIONS	
304SW	304 Stainless Steel Seal-Welded
PCY	Powder Coat Safety Yellow
GAL	Hot Dipped Galvanized

**For replacement springs, order Torsion Spring Kit (part #511686). Kit includes (1)LSG Torsion Spring, (2)Bushings and Installation Instructions.

**TO ORDER PARTS CONTACT PS SAFETY ACCESS AT
 877.446.1519 or 4psinfo@psindustries.com**

Hardware Variant for LSGPS-1520					
ITEM #	DESCRIPTION	QTY	PCY	GAL	304SW
1	LSGPS;HINGE PLATE SM ASM	1	515819	515820	516015
1.2	LSGPS;HINGE PLATE SM	1	515785	515797	516014
2	LSG;HOOP 1520	1	515996	515995	516000

Hardware Variant for LSGPS-2030					
ITEM #	DESCRIPTION	QTY	PCY	GAL	304SW
1	LSGPS;HINGE PLATE ASM	1	515776	515795	515803
1.2	LSGPS;HINGE PLATE	1	515781	515796	515807
2	LSG;HOOP 2030	1	515794	515802	516001

Hardware Variant for LSGPSD-2030					
ITEM #	DESCRIPTION	QTY ¹	PCY	GAL	304SW
1	LSGPS;HINGE PLATE SM ASM	1	515819	515820	515821
1.2	LSGPS;HINGE PLATE	1	515785	515797	515810
2	LSG;HOOP 1115	1	515793	515801	515999

Hardware Variant for LSGPSD-3040					
ITEM #	DESCRIPTION	QTY ¹	PCY	GAL	304SW
1	LSGPS;HINGE PLATE SM ASM	1	515819	515820	515821
1.2	LSGPS;HINGE PLATE	1	515785	515797	515810
2	LSG;HOOP 1520	1	515996	515995	516000

Hardware Variant for LSGPSD-4060					
ITEM #	DESCRIPTION	QTY ¹	PCY	GAL	304SW
1	LSGPS;HINGE PLATE ASM	1	515776	515795	515803
1.2	LSGPS;HINGE PLATE	1	515781	515796	515807
2	LSG;HOOP 2030	1	515794	515802	516001

1. All quantities to be doubled for Paired Gates (LSGPSD).

Replacement Parts Diagrams

XIII. Replacement Parts Diagrams

- A. These Parts Diagrams are for all PCY/GAL/304SW Models.
- B. The Replacement Parts List is located on Page 11.

FINISH OPTIONS	
304SW	304 Stainless Steel Seal-Welded
PCY	Powder Coat Safety Yellow
GAL	Hot Dipped Galvanized

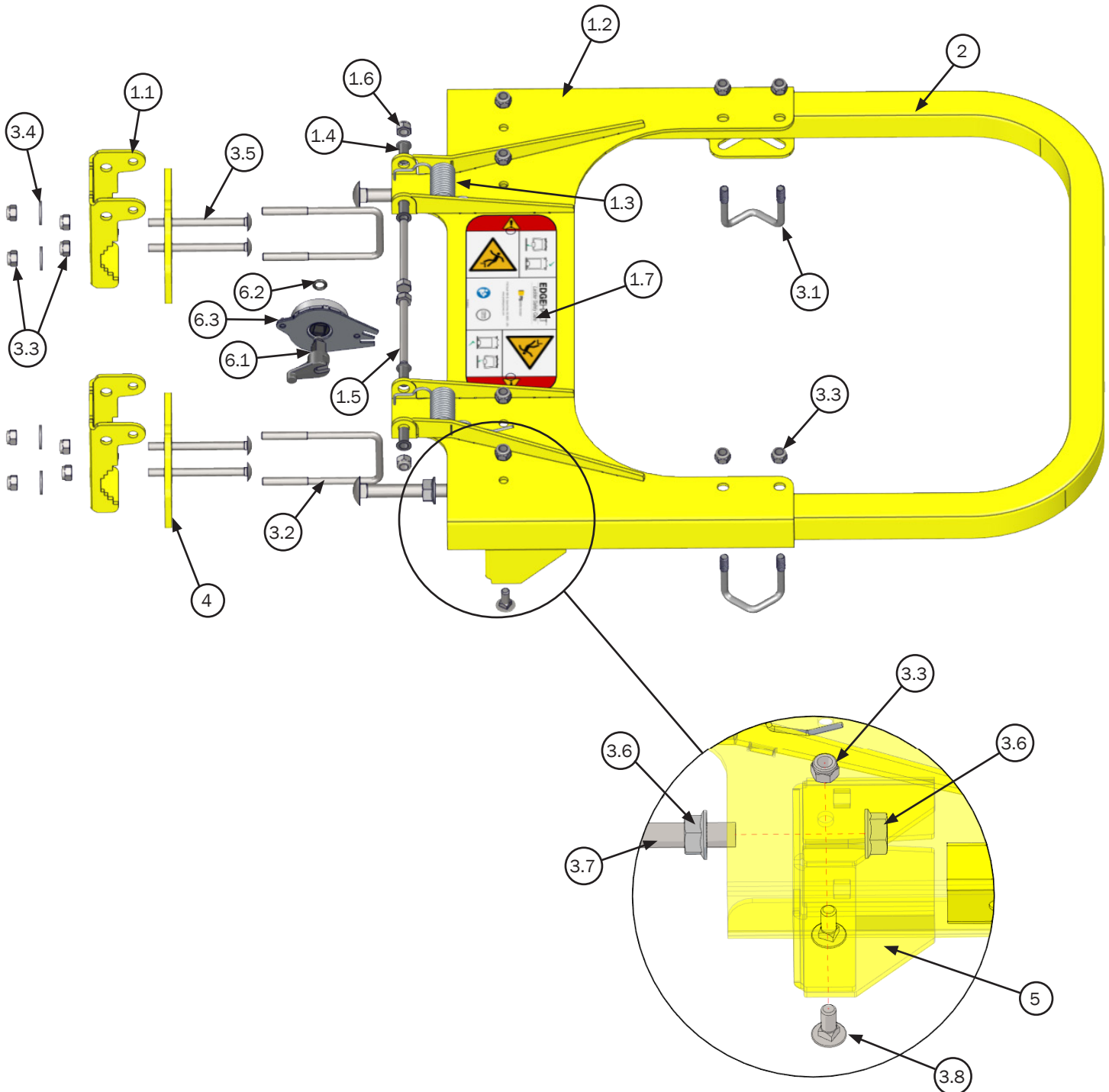

Inspection and Maintenance

XIV. Inspection and Maintenance

- A. Environmental conditions may affect the maintenance and repair requirements of the product, and recommended preventative maintenance frequency.
- B. If any of the inspection items are found to not meet the standard IMMEDIATELY “TAG OUT” the EdgeHalt® Ladder Safety Gate from active use and guard the opening until repairs are completed.

NOTICE PS Safety Access recommends that the owner implement a regular and preventative maintenance program to inspect and maintain Ladder Safety Gate at a minimum, in accordance with the recommendations in the table below.

▲ WARNING While performing maintenance and inspection ensure personnel utilize appropriate fall protection equipment and procedures.

Recommended Preventative Maintenance					
ITEM	FREQUENCY	ITEM DESCRIPTION	WHAT TO INSPECT	STANDARD	REPAIR ACTION
1	Each Use	General Housekeeping	Opening	Opening must be kept free of debris and obstructions.	Always keep area clean.
2	Weekly	Gate	Gate for corrosion or damage.	To protect the structural integrity and provide engineered safety protection.	Touch up finishes, or refinish as necessary.
			Welds and all structural components	Welds and structural components are in undamaged condition and free of dents, bends, cracks, crazing, and corrosion.	Replace component immediately.
			Gate alignment and free movement.	Gate must move freely without any interference; proper alignment with catch and self-closes to the closed position.	Adjust gate as necessary.
3	Monthly	Gate Components	Pivot Points (Bearings) for free movement.	Must be free of all debris, corrosion, and operates smoothly.	Replace as necessary.
			Location of Strike	Must be hitting the right spot evenly.	Adjust gate as necessary.
			Springs	Intact and Operating correctly.	Replace as necessary.
			Operation of Damper	Must be free of all debris, corrosion, and operates smoothly.	Replace as necessary.
			Damping Action	Gate soft closes, gate closes completely. Remove damper if it hinders operation. Damper is not required for rated safety protection. Slam-proof time will increase slightly in very cold temperatures; this is normal as damping action is affected by temperature.	There are no damper adjustments, replace if required.
4	Monthly	Structural Attachment	All Fasteners (Structural Attachment)	Fasteners must be present and be tightened to torque spec; connections pulled into firm contact by the fastener, no gaps between material.	Tighten fasteners to torque spec. Replace any missing fasteners.
5	Monthly	Labels	All labels	Manufacturer's labels in place and legible.	Replace. Contact manufacturer for FREE replacement labels.
6	After Installation	Installation Integrity	Structural integrity of gate and mounting structure.	Ensure product meets applicable safety codes and loading requirements.	Ensure all installation steps were followed completely.

PS INDUSTRIES® INCORPORATED – LIMITED WARRANTY

Limited Warranty: Subject to the terms of this Limited Warranty, PS Industries® Incorporated warrants to the original user or consumer (the "Owner") of a PS Industries product (the "Product") that, for a period of one (1) year from date of shipment, the Product will be free from defects in material and workmanship under normal use and service, and provided the Product is installed, operated and maintained in accordance with instructions supplied by PS Industries. The terms and limitations of this Limited Warranty apply to all repaired or replacement Products for a term equal to the balance of the warranty remaining on the Product that was repaired or replaced as of the date of such repair or replacement. Register online at: www.psindustries.com/contact/register-your-product

PS Flood Barriers™ Product Warranty Registration: For PS Flood Barriers™ Products, this Limited Warranty will only be valid if the Owner completes the Warranty Registration Form provided within thirty (30) days of Product installation. To request a copy of the Warranty Registration Form, contact PS Industries Incorporated, 1150 S. 48th Street, Grand Forks, ND 58201, phone 877-446-1519, email: 4psinfo@psindustries.com. Register online at: www.psindustries.com/contact/register-your-product/ Additional Warranty Registration Forms can be downloaded at www.psfloodbarriers.com/download-center/

Warranty Exclusions: Notwithstanding anything to the contrary, this Limited Warranty does not cover any of the following:

1. Normal wear and tear (including, but not limited to, normal wear and tear to gaskets and weather seals); damage or accidents resulting from freight damage, from failure to follow precautionary safety measures, or applied paint failure; abuse, misuse or unauthorized modification of the Product; misapplication; improper installation; or any defects, damage or other harm that is not the result of the acts or omissions of PS Industries.
2. Cost of field labor or other charges incurred by Owner in removing and/or re-affixing the Product or any part or component thereof.
3. Transportation costs.

Unauthorized modification of or to the Product voids this Limited Warranty. Authorized modifications, received in writing from PS Industries, as long as the modification is accomplished in strict accordance with PS Industries' instructions, does not void warranty. To request product modifications contact PS Industries, 1150 S. 48th Street, Grand Forks, ND 58201, phone 877-446-1519, email: 4psinfo@psindustries.com.

Claim Procedure: To make a claim under this Limited Warranty, the claim must be received by PS Industries before the expiration of the above stated Limited Warranty period together with proof of purchase. Contact PS Industries at the address shown below.

PS Industries Incorporated	Toll Free: 877-446-1519
Attention: Warranty	Phone: 701-746-4519
1150 S. 48th Street	Fax: 701-746-8340
Grand Forks, ND 58201	E-mail: 4psinfo@psindustries.com

An authorized PS Industries representative must be given a reasonable opportunity to inspect and investigate the alleged Product defect prior to any work being done that affects the Product or its installation. PS Industries reserves the right to charge reasonable amounts for travel and labor associated with investigation of claims. PS Industries may also require photographs of the alleged Product defect or return of the Product or part to a designated PS Industries location, freight prepaid. A return goods authorization must be received prior to the return of the Product or part. Please contact PS Industries to determine the designated location for return and to obtain the return material authorization.

Exclusive Remedy: In the event of a warranty claim that PS Industries determines to be covered by this Limited Warranty, PS Industries will replace or repair, at PS Industries' discretion, the Product or any part of the Product found to be defective.

Disclaimers: The above warranty and remedy is the sole express warranty and remedy given by PS Industries on its Product. No warranties or representations at any time made by any representative from PS Industries shall vary or expand the provisions hereof. TO THE EXTENT PERMITTED BY LAW, ALL EXPRESS AND IMPLIED WARRANTIES (INCLUDING IMPLIED WARRANTIES OF MERCHANTABILITY, FITNESS FOR A PARTICULAR PURPOSE AND NON-INFRINGEMENT) OTHER THAN THE EXPRESS LIMITED WARRANTY SET FORTH ABOVE ARE EXPRESSLY DISCLAIMED. UPON THE EXPIRATION OF THE ABOVE STATED LIMITED WARRANTY PERIOD, ANY AND ALL APPLICABLE IMPLIED WARRANTIES, INCLUDING, WITHOUT LIMITATION, WARRANTIES OF MERCHANTABILITY, FITNESS FOR A PARTICULAR PURPOSE AND NON-INFRINGEMENT, ARE DISCLAIMED. SOME STATES DO NOT ALLOW LIMITATION ON HOW LONG AN IMPLIED WARRANTY LASTS, SO THE ABOVE LIMITATION MAY NOT APPLY TO OWNER.

LIABILITY LIMITATION: In no event will PS Industries' liability to Owner or any other person or entity exceed the price paid to PS Industries for the defective Product. IN NO EVENT SHALL PS INDUSTRIES BE LIABLE TO OWNER OR ANY OTHER PERSON OR ENTITY FOR INCIDENTAL, CONSEQUENTIAL, INDIRECT OR SPECIAL DAMAGES OF ANY DESCRIPTION, WHETHER ARISING OUT OF WARRANTY (INCLUDING ANY IMPLIED WARRANTIES) OR ANY OTHER CONTRACT, STRICT LIABILITY, NEGLIGENCE OR OTHER TORT, OR OTHERWISE, INCLUDING ARISING FROM INSPECTION OR REMEDY DELAYS. SOME STATES DO NOT ALLOW THE EXCLUSION OR LIMITATION OF INCIDENTAL OR CONSEQUENTIAL DAMAGES, SO THE ABOVE LIMITATION AND EXCLUSION MAY NOT APPLY TO OWNER.

THIS WARRANTY GIVES OWNER SPECIFIC LEGAL RIGHTS AND OWNER MAY ALSO HAVE OTHER RIGHTS, WHICH VARY FROM STATE TO STATE.



877.446.1519

4psinfo@psindustries.com | psfloodbarriers.com
1150 South 48th Street | Grand Forks, ND 58201

Product Registration:
psindustries.com/contact/register-your-product